

HYDRAULIC CALIBRATION: In addition to the normal operation and adjustments, the adapter has a hydraulic calibration mode. This feature is useful for measuring correction speeds of the hydraulic valves on the machine. The Time rotary switch, calibration buttons, and dip switches 1 and 2 are used for hydraulic calibration. Contact your dealer if any additional corrections are desired.

WARRANTY: Apache Technologies, Inc. Bullseye products are warranted to be free of defects in material and workmanship for a period of two years. Electric cables and other allied equipment are warranted for a period of ninety days.

Please return the included warranty card as this will expedite any warranty service that may be required. Please retain your warranty information and proof of purchase. If a warranty card is not on file, proof of purchase must accompany your request for warranty repair.

Any evidence of abuse, misuse, alteration, accident or negligent use or an attempt to repair products by unauthorized personnel or with parts other than those provided by Apache Technologies automatically voids the warranty.

Apache Technologies liability under this warranty is limited to repairing or replacing any product returned to an authorized service center for that purpose. The foregoing states the entire liability of Apache Technologies regarding the purchase and use of its product and they shall not be held responsible for any consequential loss or damage of any kind.

This warranty is in lieu of all other warranties, expressed or implied, and constitutes all of Apache Technologies liability with respect to merchandise sold by it.



8261 State Route 235
Dayton, OH 45424 USA
Phone: 937-482-0200
Fax: 937-482-0030
www.apache-laser.com



Installation and Operating Instructions

PAA1 Adapter

***For use with
BULLSEYE® 5+, 5MC, and 6
Laser Receivers***



BULLSEYE PAA1 CONTROL SYSTEM ADAPTER

GENERAL: The Bullseye PAA1 allows a Bullseye receiver to be used with a SP™/Trimble™ Prinz Albert™ * control system. The adapter is inserted between the control box and the mast/receiver components. It will operate with 12V or 24V systems without modification. Bullseye models 5, 5MC, and 6 are compatible. If the system contains an Electric Mast, a Mast Extension Tube (MET1) is used to mount the Bullseye to the mast.

INSTALLATION: Rigid type mast - Disconnect the receiver cable from the control box and connect it to the 10-socket connector on the adapter. Connect the adapter's 10-pin pigtail connector to the control box. Mount the Bullseye receiver on the mast and connect the receiver cable 7-socket connector to the 7-pin connector on the bottom of the Bullseye.

Electric mast - Disconnect the mast cable from the control box and connect it to the 10-socket connector on the adapter. Connect the adapter's 10-pin pigtail connector to the control box. Mount the Bullseye onto the mast extension tube. Connect the coil cord 7-socket connector to the 7-pin connector on the bottom of the Bullseye.

Secure the adapter using tie wraps if necessary.

OPERATION: When power is applied, the Bullseye and the Adapter will perform a short power-up sequence, the LED's will flash and communication will be established. **The factory default settings allow the system to operate the same as the existing system without adjustment.**

ADJUSTMENT: Adjustments can be made to on-grade deadbands and fine and medium correction zones with rotary switches.

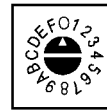
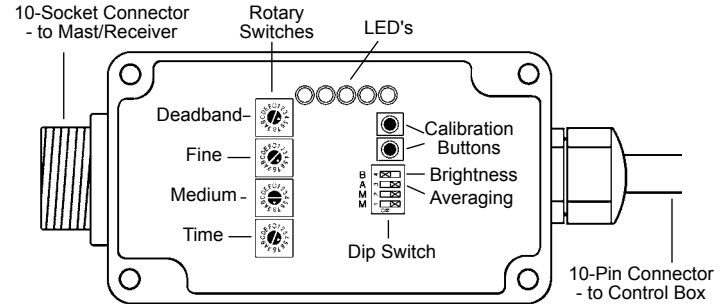
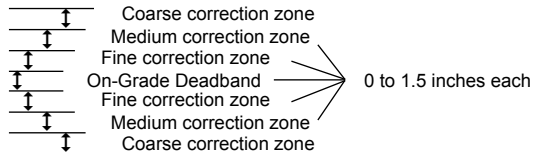
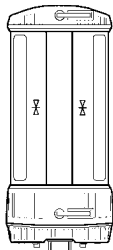

ADJUSTMENT: Each rotary switch has 16 positions. Each position represents 0.1 inch and is selectable from 0 to 1.5 inches (0 = 0 in., F = 1.5 in.). The default settings is 5 for deadband, 6 for fine, and 8 for medium. The coarse correction zone is the remainder of reception range available.

The 'Time' switch is used for hydraulic calibration mode.

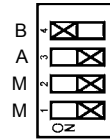

LED display brightness and beam strike averaging (a rolling 2 strike average of beam position) are selectable with dip switches. Dip Switch 4 (**B**) ON is display **Bright**; OFF is display dim. Switch 3 (**A**) ON is **Averaging** enabled; OFF is averaging disabled. Switch 1 and 2 (**M**) are used for hydraulic calibration mode and both must be in the OFF position for normal operation. The factory default setting is switch 1, 2, and 3 OFF, and switch 4 ON.

To access the switches, remove the 4 Phillips head screws of the adapter housing and remove the housing lid. Each switch is labeled on the circuit board.

LED's: An LED array inside the adapter is used for diagnostics and also shows grade readings. If there is a communication failure, the high and low LED's will flash rapidly in unison.

*Trademarks or registered trademarks of Trimble Navigation Limited.